

LEOCH RU6-512V200-M(512V200Ah)

RU6-512V200-M



LEOCH Provides Safe and Efficient LFP Battery Solutions.

LEOCH RU series adopt high safety LFP cell, with intelligent BMS management system independently developed by LEOCH, safe and reliable, excellent performance, stability and reliability, suitable for three-phase UPS backup system.

Features

- Integrated design of reserves
- CTP design, double energy density
- Cabinet occupies less volume
- Built-in gas sensor, early warning, faster intervention
- CAN/RS485 Communication output for monitoring
- Eco-friendly
- Safest lithium battery technology
- Meet UL, IEC and other authoritative international standard certifications

PACK Style



Performance data

Time(min)	5	10	15	20	30	60
Constant Power(kW)	570	512	360	270.8	185.6	96

Size

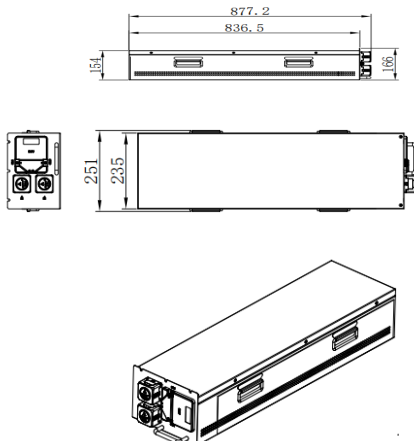

System specifications

Case Material	SPCC
Cell Type	Prismatic LiFePO ₄
Terminal Type	M8
Ingress Protection	IP20

Basic performance

Nominal Voltage	512V
Rated Capacity	200Ah
Energy	102.4kWh
Self-discharge Rate	≤3%/Month@25°C
Cycle Life	3000 times(1C/1C)
Size(W*D*H)	600*1000*2200mm
Weight	Approx.1250kg
Design Life	15 years

Charge performance

Rated Charge Current	80A
Maximum Charge Current	160A
Op. Charge Voltage	448-552V

Discharge performance

Max Output Power	570 kW @5min
Standard Discharge Time	512kW@10min
Rated Discharge Cut-off Voltage	448V
Minimum Discharge Cut-off Voltage	424V

Temperature and humidity

Discharge Temperature	-15-50°C
Charge Temperature	5-45°C
Storage Temperature	-10-45°C
Transportation Temperature	-10-45°C
Operation Humidity	5%~95%R.H
Altitude	≤2000m

Other

Communication Interface	CAN/RS485/T CP/Dry Contact
Dry Contact	DI/DO
System Parallels	≤15
Screen	Required
Thermal Management	Nature Cooling

Certification

Module: RoHS, REACH, UN38.3, UL9540A-2019
Cabinet: UL9540A-2019, UL1973, CE-EMC, IEC62619

Discharge Performance at 25°C

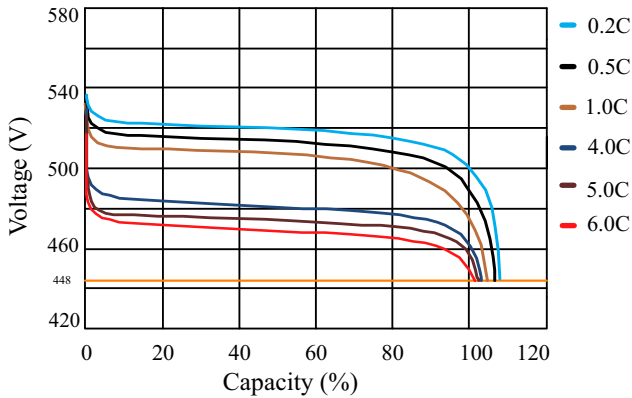

Charge and Discharge at 25°C, 0.5C

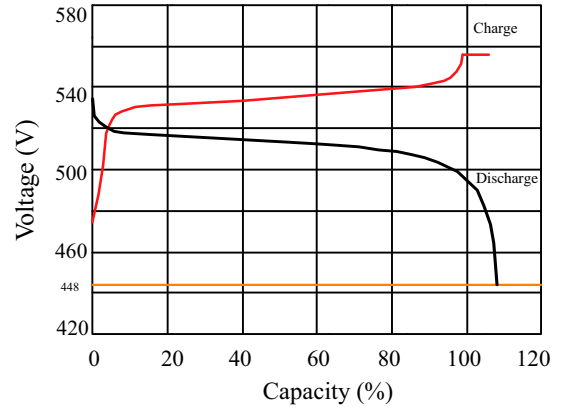

Temperature effects on capacity at 1C

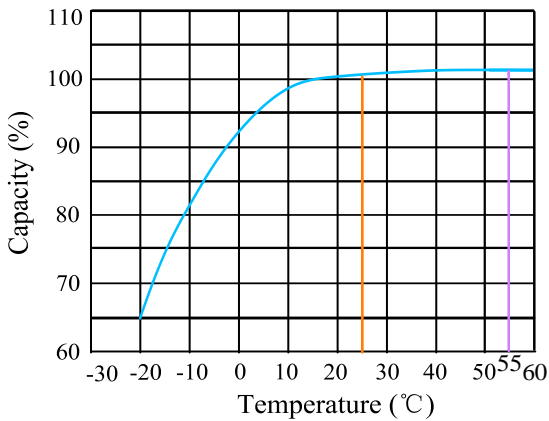

Cycle life with DOD at 25°C, 1C/1C

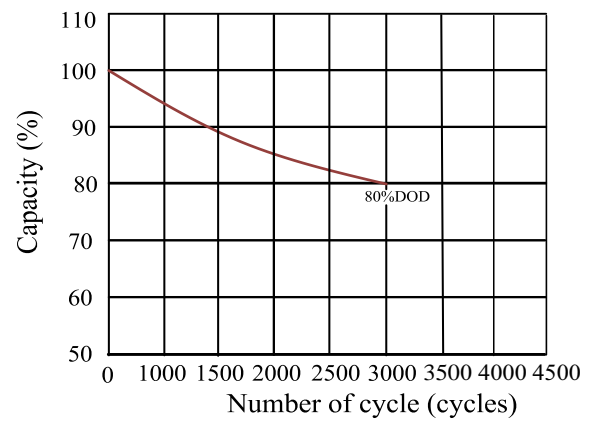

Cautions

1. Do NOT short circuit, crush or disassemble
2. Do NOT heat or incinerate.
3. Do NOT immerse in any liquid.
4. Store at 50% capacity. Recharge every 6 months. The storage area should be clean, cool, dry and ventilated.
5. Disconnect charging source prior to connecting or disconnecting battery terminals.
6. Do NOT dispose of batteries in a fire as they can explode.
7. Do NOT open, alter, or mutilate batteries. Released electrolyte is harmful to skin and eyes. It may be toxic.
8. Do NOT mix different types and brands of lithium-ion batteries.
9. Do NOT dispose in trash, follow local regulations and manufacturer's instruction.
10. See installation instructions before connecting to the supply.
11. The battery cabinet receives power from more than one source. Disconnection of all DC sources is required to De-energize this unit before installing or servicing. Wait 5 minutes before opening the unit.
12. Do NOT install on or over combustible surfaces
13. Refer to manual before servicing
14. Do NOT touch bare terminals.



Rack RU6-512V200-M